

Additional 480MHz IF output for several satellite receivers

Attention: Only for information purposes ! Modifications at your own risk ! No guarantee or responsibility for correctness or damages !

Content:

Some words about satellite tuner units ...

Standard modification for 480MHz IF-output

Instructions for:

**ECHOSTAR LT-730 & SR-8700 & LT-8700
(SHARP Tuner Type E77G27 oder G23)**

PACE PSR 800/900Plus & MSS 300/1000

**CHAPARRAL MC 115
(SHARP Tuner Type BSFA 77G23)**

**DRAKE ESR 230XT, 800XT, 2000XT
(SAMSUNG Tuner Type TBCE 35223 FD)**

Some words about satellite tuner units ...

BLOCK DIAGRAMM OF A SATELLITE TUNER

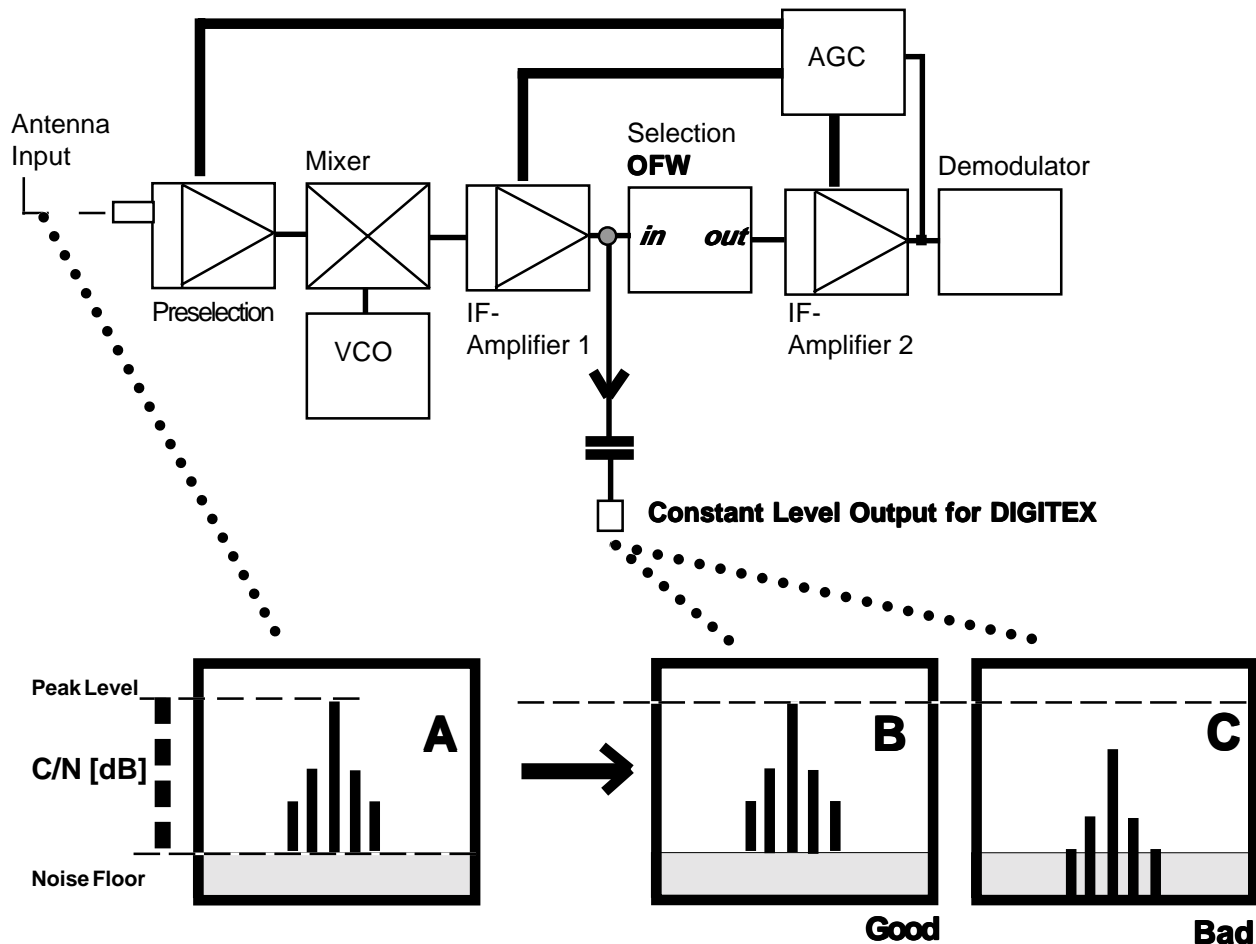

Definitions:

C/N (Carrier-to-Noise) = Peak Level - Noise Floor [dB]

Dynamic Range : Difference between upper and under Peak Level at the antenna input which delivers a constant IF-level output [dB]

The tuner unit is the heart of a satellite receiver. It converts the antenna input signal (**Picture A**) to a fixed intermediate frequency (IF). With the help of a automatic gain control (AGC) the different peak levels are regulated to a constant level (**Picture B**). This is very important for the correct performance of the following demodulator unit.

Standard tuner units are able to deliver a constant output IF-level between 50 to 80dBuV. This values are according to standard applications like ASTRA reception in Middle Europe.

High performance tuner units have a larger dynamic range between 25 to 90 dBuV.

In the case of weak signal reception the antenna input level could drop down under 50dBuV. Standard tuner units are not able to deliver a constant IF-output level under such circumstances. This means that the original carrier-to-noise level is degraded additionally (**refer to picture C**). Some outer spectral components are disappearing in the noise floor. In this way the original bandwidth is limited which means that there is also lack of information.

Some analogue "Low-Threshold-Demodulators" use this principle of bandwidth limitation. So below a certain antenna input level it is possible that a "Low-Threshold" satellite receiver delivers in this situation an acceptable picture and DIGITEX can not work in the correct way due the lack of important information.

So it is very important for the correct performance DIGITEX to deal with a constant IF-level especially under weak signal conditions.

In some cases an additional line amplifier between antenna and satellite receiver could improve the situation. But be careful; in this way the dynamic range for strong signals is restricted by the amount of the gain of the additional amplifier !

Standard modification for 480MHz IF-output

Common scheme of a satellite tuner/demodulator unit

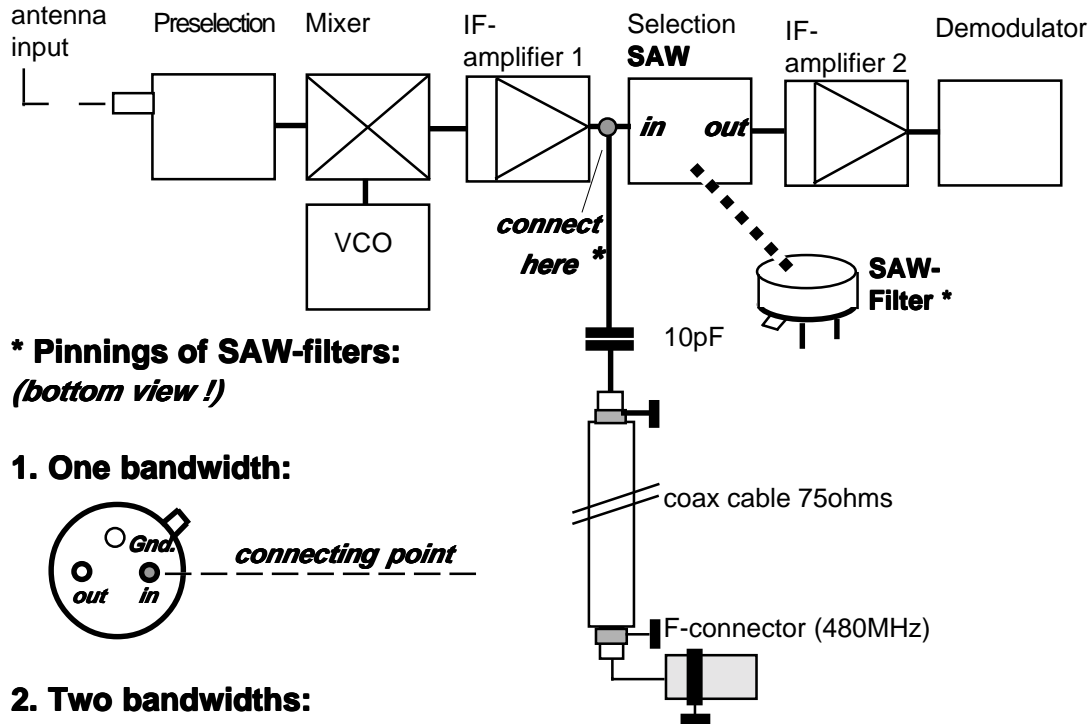

* Pinnings of SAW-filters: (bottom view !)

1. One bandwidth:

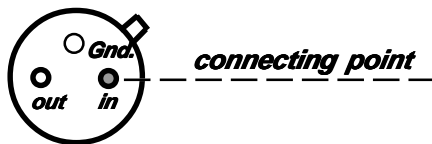

2. Two bandwidths:

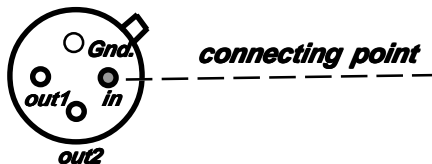

Modification

1. Remove power plug
2. Open housing of the satellite receiver
3. Remove tuner's upper shielding
4. Localize the tuner unit
5. Drill a hole (diameter 9.5mm) in the rear panel
6. Localize the SAW-filter (see upper drawing)
7. Solder a 10pF ceramic capacitor at the connecting point like shown at the upper drawing
8. Solder the other end of the capacitor at the coax cable's seal
9. Solder the coax cable's shielding at the tuner's housing (ground)
10. Mount the F-connector at the hole
11. Connect/solder the coax cable to the F-connector
(seal to inner connector/shielding to ground)

* Please note: If the SAW-output level is in the range between -60 - -40dBm you can also use the SAW-output for connecting DIGITEX which gives in some applications better results.

480MHz additional output for satellite receivers ECHOSTAR LT-730 & SR/LT-8700 (SHARP tuner type E77G27 or G23)

tuner view / component side (without shielding)

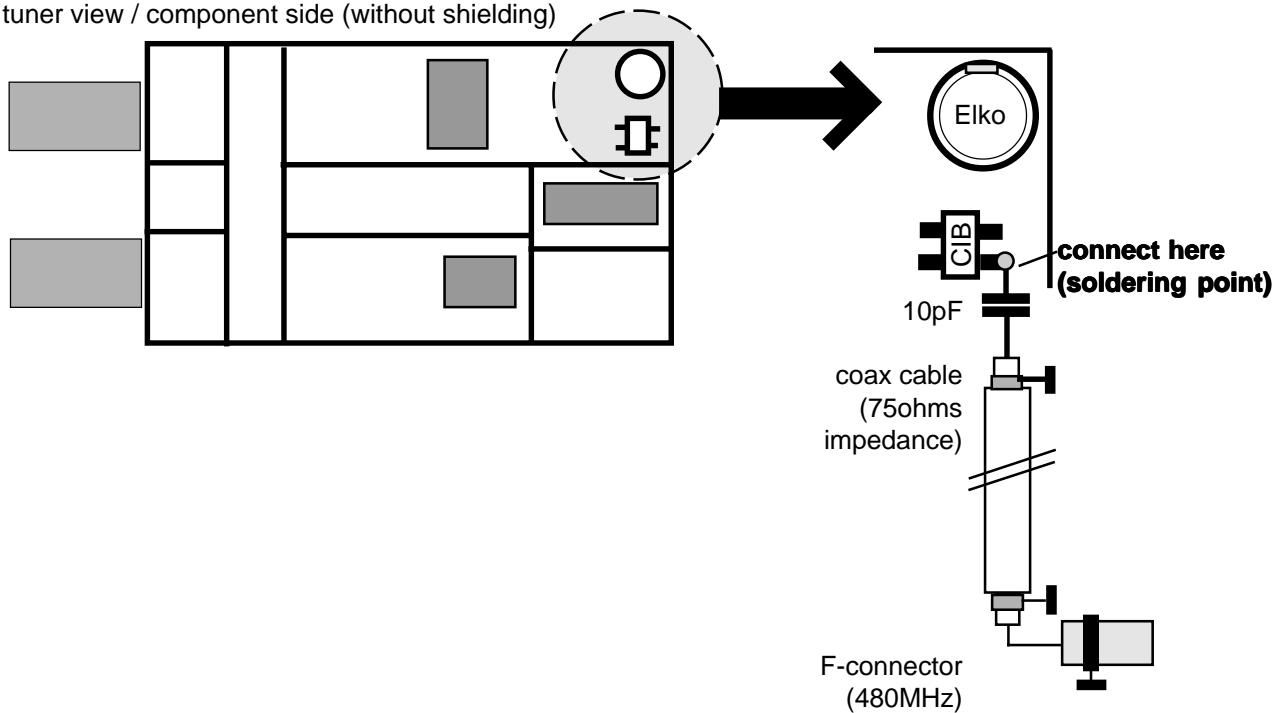

Modification

1. Remove power plug
2. Open housing of the satellite receiver
3. Remove tuner`s upper shielding
4. Drill a hole (diameter 9.5mm) in the rear panel
5. Localize SMD device "CIB" (see upper drawing)
6. Solder a 10pF ceramic capacitor at "CIB" like shown at the upper drawing
7. Solder the other end of the capacitor at the coax cabel`s seal
8. Solder the coax cable`s shielding at the tuner`s housing (ground)
9. Mount the F-connector at the hole
10. Connect/solder the coax cable to the F-connector
(seal to inner connector/shielding to ground)

Attention: The G23-tuner unit has about 5-10dB less 480MHz IF-signal output which could be to less for DIGITEX. In this case we recommend our **universal broadband 70 - 480MHz amplifier** which will raise the level for about 28dB.

480MHz additional output for satellite receivers PACE PSR 800/900Plus & MSS 300/1000

tuner view / component side (without shielding)

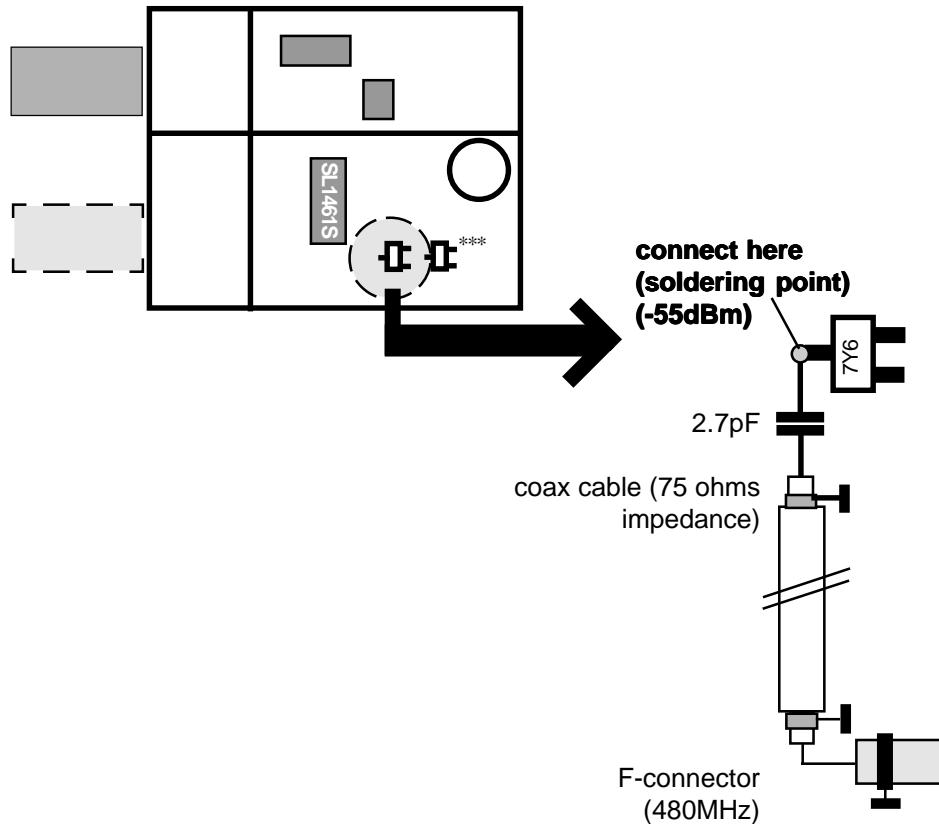

Modification

1. Remove power plug
2. Open housing of the satellite receiver
3. Remove tuner's upper shielding
4. Drill a hole (diameter 9.5mm) in the rear panel
5. Localize SMD device "7Y6" (right position to IC SL 1461S / see upper drawing)
***Caution: There is also a second device "7Y6" !
6. Solder a 2.7pF ceramic capacitor at "7Y6" like shown at the upper drawing
7. Solder the other end of the capacitor at the coax cable's seal
8. Solder the coax cable's shielding at the tuner's housing (ground)
9. Mount the F-connector at the hole
10. Connect/solder the coax cable to the F-connector
(seal to inner connector/shielding to ground)

Attention: The tuner unit has about 5-10dB less 480MHz IF-signal output which could be to less for DIGITEX. In this case we recommend our **universal broadband 70 - 480MHz amplifier** which will raise the level for about 28dB.

480MHz additional output for satellite receiver CHAPARRAL MC 115 (SHARP tuner type BSFA 77G23)

tuner view / component side (without shielding)

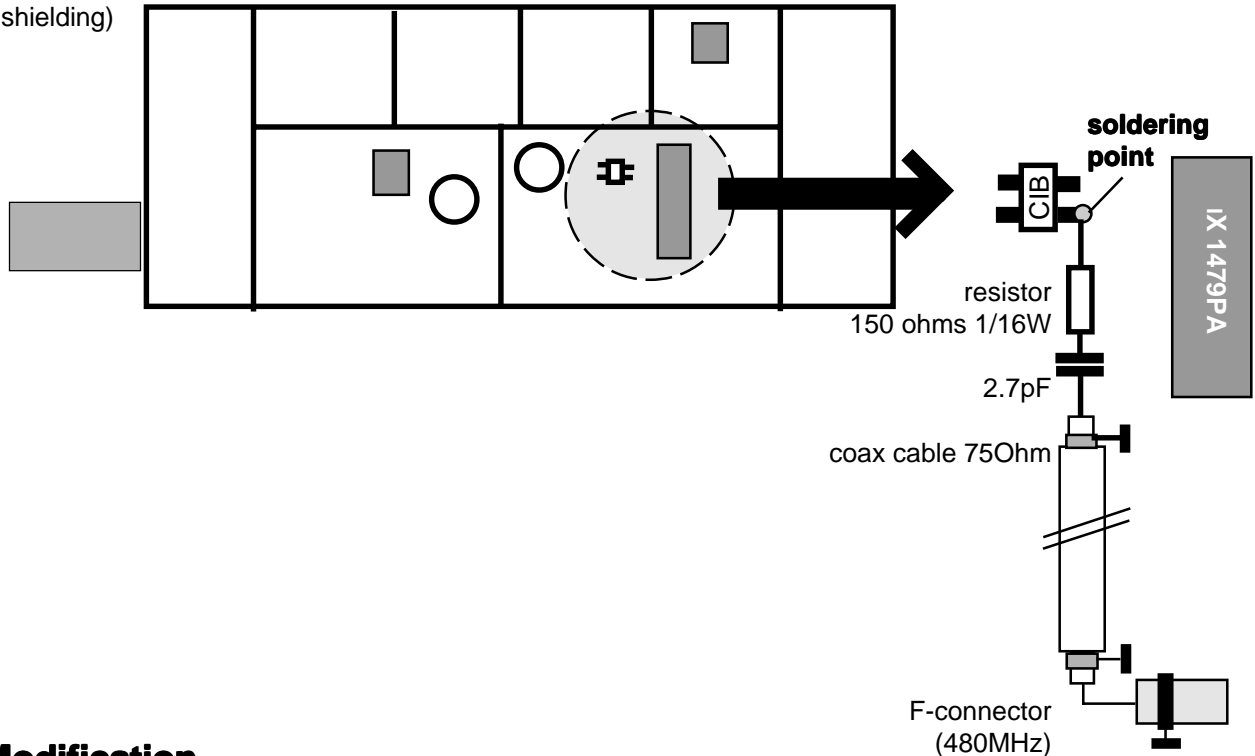

Modification

1. Remove power plug
2. Open housing of the satellite receiver
3. Remove main board
4. Remove tuner`s upper shielding
5. Drill a hole (diameter 9.5mm) in the rear panel
6. Localize SMD device "CIB" (see upper drawing)

Attention: There is a second (wrong) device "CIA" near the "CIB" device

7. Solder a 150 ohms resistor in series with a 10pF ceramic capacitor at "CIB" like shown at the upper drawing
8. Solder the other end of the capacitor at the coax cable`s seal
9. Solder the coax cable`s shielding at the tuner`s housing (ground)
10. Mount the F-connector at the hole
10. Connect/solder the coax cable to the F-connector
(seal to inner connector/shielding to ground)

Please note: In some cases it is possible that the IF level of this tuner type is too low for direct connection of DIGITEX. Therefore we recommend the insertion of our IF broadband amplifier.

480MHz additional output for satellite receiver DRAKE ESR 230XT, 800XT, 2000XT (SAMSUNG tuner type TBCE 35223 FD)

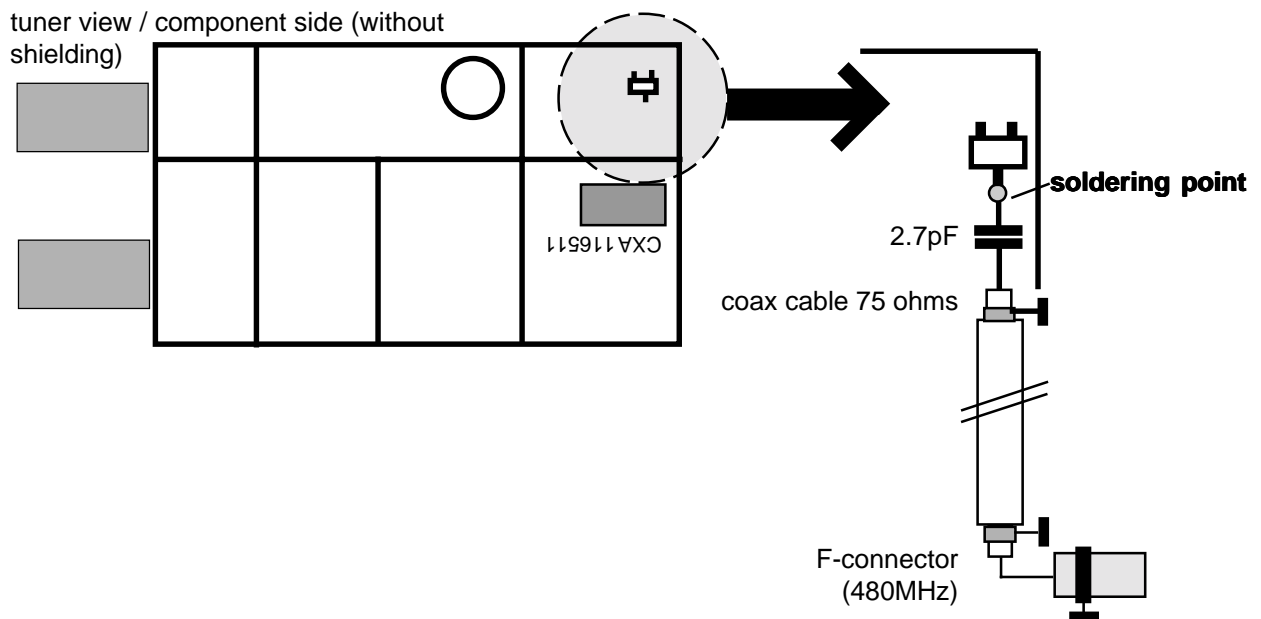

Modification

1. Remove power plug
2. Open housing of the satellite receiver
3. Remove tuner's upper shielding
4. Drill a hole (diameter 9.5mm) in the rear panel
5. Localize SMD device near the shielding (see upper drawing)
- ***Caution: There is also a second device at the left side of this device !
6. Solder a 2.7pF ceramic capacitor at the center pin of the SMD device like shown at the upper drawing
7. Solder the other end of the capacitor at the coax cable's seal
8. Solder the coax cable's shielding at the tuner's housing (ground)
9. Mount the F-connector at the hole
10. Connect/solder the coax cable to the F-connector (seal to inner connector/shielding to ground)